

Hinge- Mortise Mount

HINGE

JCP Models Description

J-7-9001 Mortise Hinge x US32D

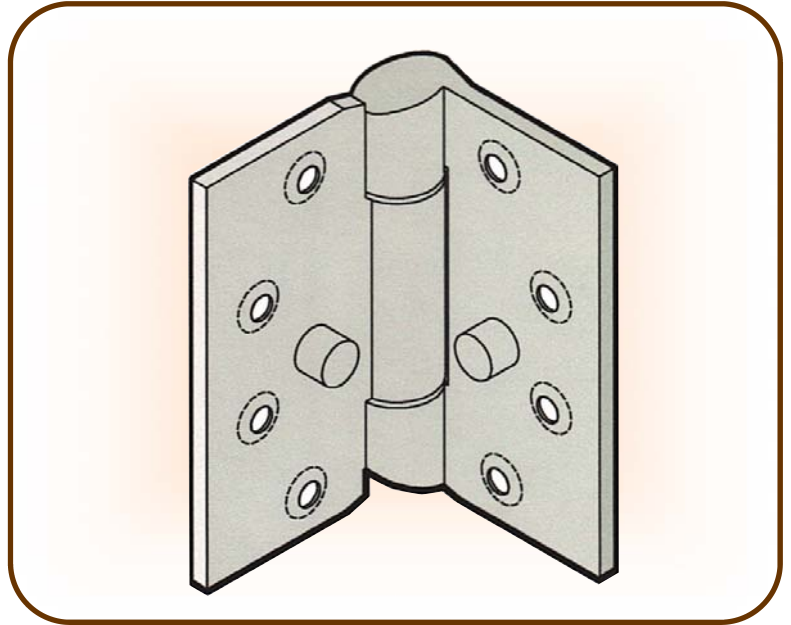

JCP Specifications: The JCP mortise hinge is 4-1/2" x 4-1/2" x 3/16" thick investment cast stainless steel with a US32D finish and a security stud on each hinge leaf. The hinge has hospital tips, a stainless steel pin that is concealed and non-removable, and maintenance-free anti-friction bearings. The hinge is supplied with Torx® w/ pin security screws and meets ANSI/BHMA A156.7, NFPA 80, and the NAAMM standard HMMA 863-96.

Always verify that you have the correct template for your specific project.



JAILS CORRECTIONAL PRODUCTS A Division of **FABCOR, Inc.**

350 South Ohio Street, P.O. Box 58
Minster, Ohio 45865
www.fabcor.com

Phone: (419) 628- 4428
Fax: (419) 628- 2899
E-mail: jails@fabcor.com

Hardware Assembly

HA-04.01

Revision C

©2003 Fabcor, Inc.